

REGÜLATÖR SİPARİŞ FORMU
OVERSPEED GOVERNOR ORDER FORM

FİRMA ADI / COMPANY NAME	TELEFON / TELEPHONE
FİRMA ADRESİ / COMPANY ADDRESS	FAKS / FAX
SEVK ADRESİ / ADDRESS OF SHIPMENT	SİPARİŞ TARİHİ / ORDER DATE
FİRMA YETKİLİSİ / COMPANY AUTHORITY	TESLİM TARİHİ / DELIVERY TIME

REGÜLATÖR ÇAP 235 mm (OSG A)
OVERSPEED GOVERNOR Ø235 mm

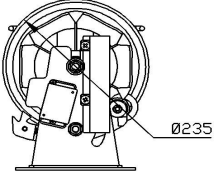

Ø235

ADET / QUANTITY

0,30 m/s	0,40 m/s	0,50 m/s	0,63 m/s	0,80 m/s	1,00 m/s
<input type="checkbox"/>	<input type="checkbox"/>	<input type="checkbox"/>	<input type="checkbox"/>	<input type="checkbox"/>	<input type="checkbox"/>
1,20 m/s	1,60 m/s				
<input type="checkbox"/>	<input type="checkbox"/>				

REGÜLATÖR ÇAP 315 mm (OSG B)
OVERSPEED GOVERNOR Ø315 mm

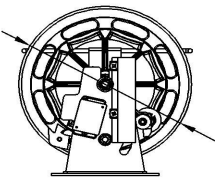

Ø315

ADET / QUANTITY

0,63 m/s	0,80 m/s	1,00 m/s	1,20 m/s	1,60 m/s	1,75 m/s
<input type="checkbox"/>	<input type="checkbox"/>	<input type="checkbox"/>	<input type="checkbox"/>	<input type="checkbox"/>	<input type="checkbox"/>
2,00 m/s					
<input type="checkbox"/>					

REGÜLATÖR ÇAP 235 mm (SSG)
OVERSPEED GOVERNOR Ø235 mm

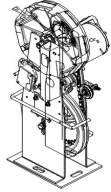

ADET / QUANTITY

0,10 m/s	0,15 m/s	0,20 m/s	0,25 m/s	0,30 m/s	0,35 m/s
<input type="checkbox"/>	<input type="checkbox"/>	<input type="checkbox"/>	<input type="checkbox"/>	<input type="checkbox"/>	<input type="checkbox"/>
0,40 m/s					
<input type="checkbox"/>					

GERGİ KASNAĞI + 25 KG AĞIRLIK
TENSION PULLEY + WEIGHT 25 KG

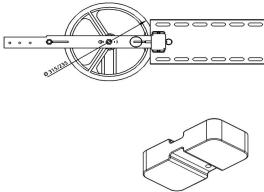

ADET / QUANTITY

Ø200 mm	Ø235 mm	Ø315 mm	PLASTİK KASNAK / PLASTIC PULLEY	DÖKÜM KASNAK / CAST IRON PULLEY
<input type="checkbox"/>	<input type="checkbox"/>	<input type="checkbox"/>	<input type="checkbox"/>	<input type="checkbox"/>

GERGİ KASNAĞI + 12 KG AĞIRLIK
TENSION PULLEY + WEIGHT 12 KG

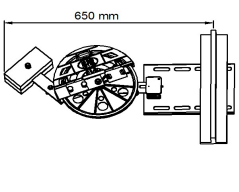

650 mm

ADET / QUANTITY

Ø200 mm	Ø235 mm	Ø315 mm	PLASTİK KASNAK / PLASTIC PULLEY	DÖKÜM KASNAK / CAST IRON PULLEY
<input type="checkbox"/>	<input type="checkbox"/>	<input type="checkbox"/>	<input type="checkbox"/>	<input type="checkbox"/>

GERGİ KASNAĞI / AĞIRLIKSIZ
TENSION PULLEY / NO WEIGHT

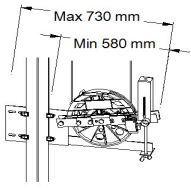

Max 730 mm
Min 580 mm

ADET / QUANTITY

Ø200 mm	Ø235 mm	Ø315 mm	PLASTİK KASNAK / PLASTIC PULLEY	DÖKÜM KASNAK / CAST IRON PULLEY
<input type="checkbox"/>	<input type="checkbox"/>	<input type="checkbox"/>	<input type="checkbox"/>	<input type="checkbox"/>

UCM BOBİN (A3)
UCM COIL

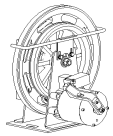

ADET / QUANTITY

24 VDC	190 VDC			
<input type="checkbox"/>	<input type="checkbox"/>			

UZAKTAN KONTROL (MRL)
REMOTE CONTROL (MRL)

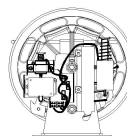

ADET / QUANTITY

24 VDC	190 VDC			
<input type="checkbox"/>	<input type="checkbox"/>			

ENCODER DİŞLİSİ (ENCODER HAZIRLIK)
ENCODER GEAR (ENCODER PREPARATION)

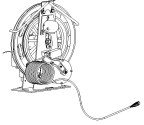

ADET / QUANTITY

1024 PULSE ENCODER DAHİL / INCLUDE ENCODER	360 PULSE ENCODER DAHİL / INCLUDE ENCODER PULSE ENCODER DAHİL / INCLUDE ENCODER
<input type="checkbox"/>	<input type="checkbox"/>	<input type="checkbox"/>

PLASTİK MUHAFAZA / PROTECTION COVER PLASTIC



ADET / QUANTITY

YARIM KORUMA / HALF PROTECTION	TAM KORUMA / FULL PROTECTION			
<input type="checkbox"/>	<input type="checkbox"/>			

SAC MUHAFAZA / PROTECTION COVER SHEET IRON



ADET / QUANTITY

AĞIRLIK / WEIGHT

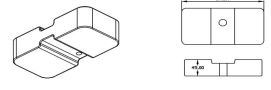

ADET / QUANTITY

25 KG PIK DÖKÜM / CAST IRON	25 KG PLASTİK KAPLAMA / PLASTIC COVER	12 KG PIK DÖKÜM / CAST IRON	12 KG PLASTİK KAPLAMA / PLASTIC COVER
<input type="checkbox"/>	<input type="checkbox"/>	<input type="checkbox"/>	<input type="checkbox"/>