

**TAHRİK KASNAĞI SİPARİŞ FORMU**  
ORDER FORM OF TRACTION PULLEYS

<b>FİRMA ADI / COMPANY NAME</b>	<b>TELEFON / TELEPHONE</b>
<b>FİRMA ADRESİ / COMPANY ADDRESS</b>	<b>FAKS / FAX</b>
<b>SEVK ADRESİ / ADDRESS OF SHIPMENT</b>	<b>SİPARİŞ TARİHİ / ORDER DATE</b>
<b>FİRMA YETKİLİSİ / COMPANY AUTHORITY</b>	<b>TESLİM TARİHİ / DELIVERY TIME</b>

KASNAK DETAYLARI / PULLEY DETAILS		ÖLÇÜLER / DIMENSIONS	
KASNAK ÇAP / DIAMETER OF PULLEY		A=	I=
HALAT SAYISI / NUMBER OF ROPE		B=	J=
HALAT ÇAP / ROPE DIAMETER		C=	K=
MAKİNA ADI VE MODELİ / TRACTION MAC. NAME & TYPE		D=	L=
MİL ÇAP / AXLE DIAMETER	mm	E=	
HALAT MERKEZLERİ / ROPE AXLE ( C )	mm	F=	
MİL ÇAP İŞLENECEK / AXLE HOLE MACHINED	<input type="checkbox"/> EVET YES <input type="checkbox"/> HAYIR NO	G=	
ADET / QUANTITY		H=	

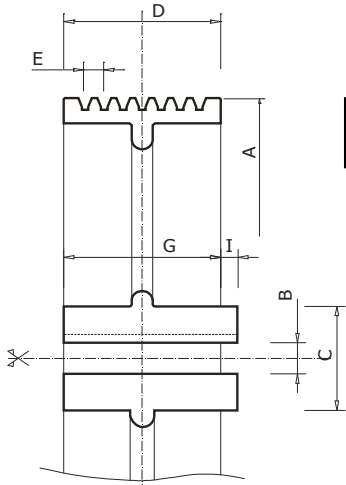

**TİP1**  
**TYPE1**

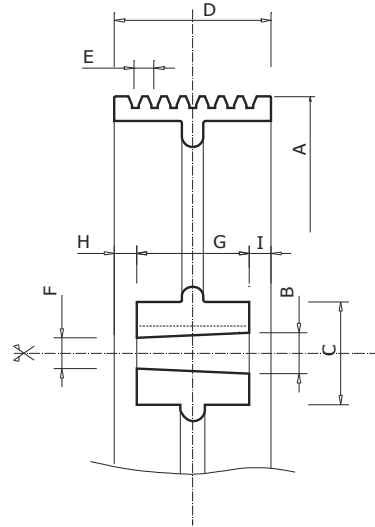

**TİP2**  
**TYPE2**

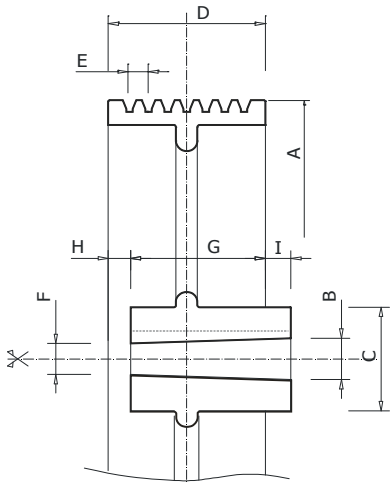

**TİP3**  
**TYPE3**

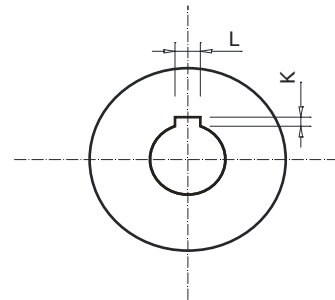

**MİL DETAYI**  
**HOLE DETAIL**

BİLDİRİŞ OLDUĞUNUZ KASNAK MİL ÇAPINDAKİ, TOLERANSLARIN STANDARTLARIN DIŞINDA OLMASI HALİNDE SORUMLULUK FİRMANIZA AİTTİR.

ACCORDING TO YOUR INFORM ABOUT PULLEY AXLE HOLE IF TOLERANCE EXCEPT THE STANDART, THE RESPONSIBILITY BELONGS TO YOUR COMPANY.